

Installation Manual

6549000D

50 Hz

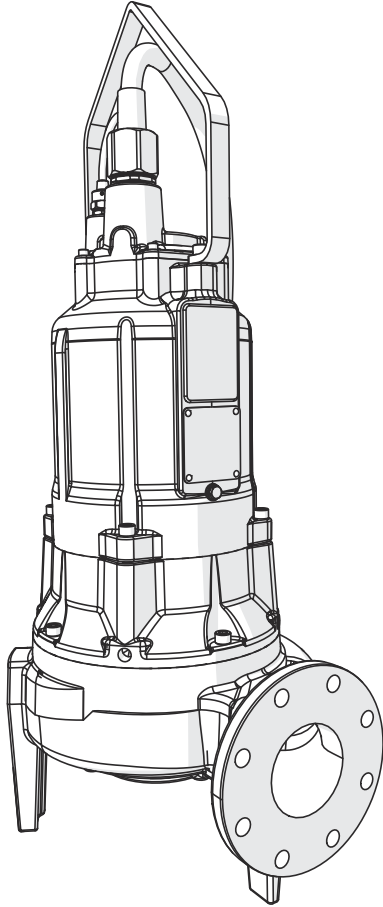

3LV-Series
3–10 hp

3LE-Series
3–10 hp

3LM-Series
3–7.5 hp

Ordinary Location Models

Tested to CSA and
UL standards

3" Solids Handling Sewage Pumps



For pressure sewer applications, verify a Redundant Check Valve Assembly (curb stop and check valve) is installed between the pump discharge and the street main, as close to the public right-of-way as possible, on all installations to protect from system pressures.

NOTICE

Installer: manual must remain with owner or system operator/maintainer.

Record information:

Model: _____

Serial: _____

Control Panel: _____

Mfg Date: _____

Install Date: _____

Dealer: _____

Dealer Ph: _____



Liberty Pumps®





Engineered**Products**

7000 Apple Tree Avenue
Bergen, NY 14416
ph: 1-800-543-2550
fax: 1-585-494-1839
www.LibertyPumps.com/LEP/INT

Contents

Safety Precautions	2 EN
General Information	4 EN
Operating Constraints	4 EN
Inspection and Storage	4 EN
Model Specifications	4 EN
Pump System Components	4 EN
Wiring Instructions	5 EN
Preparation	7 EN
Installation	8 EN
Operation	9 EN
Maintenance and Troubleshooting	10 EN
Warranty	14 EN

Safety Guidelines

	This safety alert symbol is used in the manual and on the pump to alert of potential risk for serious injury or death.
	This safety alert symbol identifies risk of electric shock . It is accompanied with an instruction intended to minimize potential risk of electric shock.
	This safety alert symbol identifies risk of fire . It is accompanied with an instruction intended to minimize potential risk of fire.
	This safety alert symbol identifies risk of serious injury or death . It is accompanied with an instruction intended to minimize potential risk of injury or death.
⚠ DANGER	Warns of hazards which if not avoided will result in serious injury or death.
⚠ WARNING	Warns of hazards which if not avoided could result in serious injury or death.
⚠ CAUTION	Warns of hazards which if not avoided could result in minor or moderate injury.
NOTICE	Signals an important instruction related to the pump. Failure to follow these instructions could result in pump failure or property damage.

⚠ WARNING Read every supplied manual before using pump system. Follow all the safety instructions in manual(s) and on the pump. Failure to do so could result in serious injury or death.

Safety Precautions

⚠ WARNING **RISK OF ELECTRIC SHOCK**

- Accidental contact with electrically live parts, items, fluid, or water can cause serious injury or death.
- Always disconnect pump(s) from power source(s) before handling or making any adjustments to either the pump(s), the pump system, or the control panel.
- All installation and maintenance of pumps, controls, protection devices, and general wiring shall be done by qualified personnel.
- All electrical and safety practices shall be in accordance with the National Electrical Code[®], the Occupational Safety and Health Administration, or applicable local codes and ordinances.
- Do not remove cord and strain relief, and do not connect conduit to pump.
- Pump shall be properly grounded using its supplied grounding conductor. Do not bypass grounding wires or remove ground prong from attachment plugs. Failure to properly ground the pump system can cause all metal portions of the pump and its surroundings to become energized.
- Do not handle or unplug the pump with wet hands, when standing on damp surface, or in water unless wearing Personal Protective Equipment.
- Always wear dielectric rubber boots and other applicable Personal Protective Equipment (PPE) when water is on the floor and an energized pump system must be serviced, as submerged electrical connections can energize the water. Do not enter the water if the water level is higher than the PPE protection or if the PPE is not watertight.
- Do not lift or carry a pump or a float assembly by its power cord. This will damage the power cord, and could expose the electrically live wires inside the power cord.
- The electrical power supply shall be located within the length limitations of the pump power cord, and for below grade installations it shall be at least 4 ft (1.22 m) above floor level.
- Do not use this product in applications where human contact with the pumped fluid is common (such as swimming pools, fountains, marine areas, etc.).
- Protect the power and control cords from the environment. Unprotected power and control (switch) cords can allow water to wick through ends into pump or switch housings, causing surroundings to become energized.

⚠ WARNING **RISK OF FIRE**

- Do not use an extension cord to power the product. Extension cords can overload both the product and extension cord supply wires. Overloaded wires will get very hot and can catch on fire.
- Do not use this product with or near flammable or explosive fluids such as gasoline, fuel oil, kerosene, etc. If rotating elements inside pump strike any foreign object, sparks may occur. Sparks could ignite flammable liquids.

- This product requires a separate, properly fused and grounded branch circuit, sized for the voltage and amperage requirements of the pump, as noted on the nameplate. Overloaded branch circuit wires will get very hot and can catch on fire. When used, electrical outlets shall be simplex of the appropriate rating.
- For ordinary location pump cord replacement: power cord must be of the same length and type as originally installed on the Liberty Pumps product. Use of incorrect cord may lead to exceeding the electrical rating of the cord and could result in death, serious injury, or other significant failure.
- Sewage and effluent systems produce and may contain flammable and explosive gases. Prevent introduction of foreign objects into basin as sparks could ignite these gases. Exercise caution using tools and do not use electronic devices or have live, exposed electrical circuits in or around basins, open covers and vents.
- Ordinary location pumps are not to be installed in locations classified as hazardous in accordance with the National Electric Code®, ANSI/NFPA 70.

- Keep clear of suction and discharge openings. To prevent injury, never insert fingers into pump while it is connected to a power source.
- Do not use this ordinary location product with flammable, explosive, or corrosive fluids. Do not use in a flammable and/or explosive atmosphere as serious injury or death could result.
- This product contains chemicals known to the State of California to cause cancer and birth defects or other reproductive harm. www.p65warnings.ca.gov.

⚠ CAUTION

- ◆ This pump has been evaluated for use with water only, however use with human waste and toilet paper is permitted.

NOTICE

- ◆ **For pressure sewer applications**, verify a Redundant Check Valve Assembly (curb stop and check valve) is installed between the pump discharge and the street main, as close to the public right-of-way as possible, on all installations to protect from system pressures.
- ◆ Verify 3-phase pumps for correct rotation prior to installing pump(s) in basin. To change rotation, reverse any two of the three power leads to the pump (not the ground). Code the wires for reconnection after installation.
- ◆ Do not dispose of materials such as paint thinner or other chemicals down drains. Doing so could chemically attack and damage pump system components and cause product malfunction or failure.
- ◆ Do not use pump system with mud, sand, cement, hydrocarbons, grease, or chemicals. Pump and system components can be damaged from these items causing product malfunction or failure. Additionally, flooding can occur if these items jam the impeller or piping.
- ◆ Do not use pumps with fluid over 104°F (40°C). Operating the pump in fluid above this temperature can overheat the pump, resulting in pump failure and excessive cavitation.
- ◆ Submersible Pump—do not run dry.
- ◆ The Uniform Plumbing Code® states that sewage systems shall have an audio and visual alarm that signals a malfunction of the system, to reduce the potential for property damage.
- ◆ Keep pump upright.
- ◆ Do not allow pump to freeze.
- ◆ At no time shall the pump be stored within an incomplete wet pit. The pump shall not be placed into the pit until it can be fully operational.
- ◆ Replacement impellers must match the part number of original impeller installed from the factory. Do not trim impellers without consulting the factory.

⚠ WARNING **RISK OF SERIOUS INJURY OR DEATH**

- Energizing the control panel or breaker for the first time is potentially dangerous. Licensed electrical personnel should be present when the panel or breaker is energized for the first time. If faults caused by damage or poor installation practices have not been detected, serious damage, injury or death can result when power is applied.
- Do not modify the pump/pump system in any way. Modifications may affect seals, change the electrical loading of the pump, or damage the pump and its components.
- All pump/pump system installations shall be in compliance with all applicable Federal, State, and Local codes and ordinances.
- Do not allow children to play with the pump system.
- Do not allow any person who is unqualified to have contact with this pump system. Any person who is unaware of the dangers of this pump system, or has not read this manual, can easily be injured by the pump system.
- In 200/230V installations, one side of the line going to the pump is always “hot”, whether the float switch is on or off. To avoid hazards, install a double pole disconnect near the pump installation.
- Vent basin in accordance with local code. Proper venting of sewer and effluent gases alleviates poisonous gas buildup and reduces the risk of explosion and fire from these flammable gases.
- Wear adequate Personal Protective Equipment when working on pumps or piping that have been exposed to wastewater. Sump and sewage pumps often handle materials that can transmit illness or disease upon contact with skin and other tissues.
- Do not enter a pump basin after it has been used. Sewage and effluent can emit several gases that are poisonous.
- Do not remove any tags or labels from the pump or its cord.

General Information

This manual contains important information for the safe installation and use of this product. Make sure this manual is provided to the owner of the equipment or to the responsible party who maintains the system.

These LEP-Series pumps are to be used for handling septic tank effluent, sewage, and drain (storm) water.

Provide pump serial number in all correspondence and reports.

Complete the Start-Up Report as installation progresses. Completed and submitted Report is required for warranty. Retain Report for reference. www.libertypumps.com/lep/int/Services/Warranty

Pumps are tested to CSA and UL standards.

Operating Constraints

It is extremely important to verify that the pump has been sized correctly for the intended installation. The operating point of the pump must lie within the acceptable range as outlined by the applicable Liberty Pumps performance chart. Operating the pump outside of the recommended range can invalidate the CSA Certification of the pump and can also cause damage and premature failure. Operating outside of the recommended range can cause the pump to exceed its rated nameplate amp draw, which will void the pump certification. It can also cause motor overheating, cavitation, excessive vibration, clogging, and poor energy efficiency.

Inspection and Storage

Initial Inspection

The pump should be immediately inspected for damage that may have occurred in shipment.

1. Visually check the pump and any spare parts for damage.
2. Check for damaged electrical wires, especially where they exit the motor housing.

Contact Liberty Pumps customer service to report any damage or shortage of parts.

Storage Before Use

⚠️ WARNING RISK OF ELECTRIC SHOCK

- Protect the power and control cords from the environment. Unprotected power and control (switch) cords can allow water to wick through ends into pump or switch housings, causing surroundings to become energized.

NOTICE

- ◆ At no time shall the pump be stored within an incomplete wet pit. The pump shall not be placed into the pit until it can be fully operational.

LEP-Series pumps are shipped from the factory ready for installation and use. The pump shall be held in storage if the pump station is not complete. If storage is necessary, the pump should remain in its shipping container. It should be stored in a warehouse or storage shed that has a clean, dry temperature-stable environment where the pump and its container shall be covered to protect it from water, dirt, vibration, etc. The cord ends must be protected against moisture. Do not allow the pump to freeze.

Uninstalled pumps that are idle for periods of time greater than three months should have impellers manually rotated once a month to lubricate the upper (inner) and lower (outer) seals.

Model Specifications

For complete listing of models and their specifications, refer to www.libertypumps.com/lep/int/About/Engineering-Specs. Pump nameplate provides a record of specific pump information.

Pump System Components

Control Panel

All LEP-Series pumps require a separate, approved pump control panel for operation. Operation of these models will be according to the control selected; see separate operation instructions supplied with the unit.

IMPORTANT: When connecting an LEP-Series pump to an existing control panel, verify the panel is correctly sized and equipped for the pump.

Control and power cords shall not be spliced, although a junction box may be used. Verify the electrical specifications for the control panel properly match those of the pump. 3-phase models require overload elements selected or adjusted in accordance with the control panel instructions.

The panel must have provisions for the thermostats that open the motor contactors. Do not exceed voltage/current combinations for the thermostat: 24 VAC/125 VA, and 110–600 VAC/345 VA. Thermostats are designed to open at 125°C.

Overload Protection

LEP-Series pumps require overload protection in the control panel. The motor control unit shall be approved and shall be properly sized or adjusted for the full load input power indicated on the pump nameplate. It is important to properly adjust or select the motor control overload protection. The full load amperes on the nameplate should be used as a baseline, but it is important to consider that events such as supply voltage variation or large solids passing through the pump can temporarily increase current draw. To avoid possible nuisance tripping, it may be necessary to adjust overloads to a value slightly higher than the full load input power indicated on the pump nameplate.

Thermostats

Dual seal LEP-Series motors have hermetically sealed heat sensors (thermostats) embedded in the motor windings to detect overheat conditions and prevent damage to the motor. The thermostats are a normally closed (NC) switch that will open in the presence of excessive motor temperature. The thermostats will automatically reset when the motor has cooled to a safe temperature. The thermostats shall be wired to interrupt power to the motor contactor with a relay in the panel (cut power to the motor) if the thermostats open due to motor overheating. The pump will resume operation once the thermostats automatically reset. If there is a need to log or monitor over-temperature events, an external device will be needed. Tripping of the thermostats indicates an issue that should be investigated. Liberty Pumps control panels contain the proper circuitry to protect the motor in the event of overheat conditions.

Motors contain three thermostats connected in series. The thermostats are set to open at 257°F (125°C) and automatically close at 221°F (105°C). These pumps are designed to operate under class B thresholds with a maximum temperature of 266°F (130°C), even though the motors are constructed with class H materials.

Seal Failure Probes

Dual seal LEP-Series pumps have a leak detection device mounted in an oil-filled cavity located between the two mechanical shaft seals. The device consists of two probes with a 200k Ω resistor mounted between them. The circuit can be tested by checking for continuity between the seal leak wires; refer to wiring diagram. If the lower (outer) shaft seal begins to leak and water migrates into the cavity, it will be detected. Once a shaft seal failure is detected, the pump will continue to operate but service should be scheduled as soon as possible.

The LEP-Series control panels by Liberty Pumps have a seal leak detection system with a test button that monitors the integrity of the seal leak circuit and components. When pressed, the light should illuminate. The light should go off when the test button is released. If it remains on, the potentiometer is set too high. If the light does not illuminate, the light is burned out, the circuitry is open, or the system does not have power. The seal leak relay requires adjustment upon installation. See **Seal leak relay setup** on page 9.

Seal fail probes connect to a relay in the control panel, which is included in a Liberty Pumps control panel. For a non-Liberty Pumps control panel or for a replacement relay, refer to Table 1.

Table 1. Seal Fail Replacement Relay

Description	Relay Input Voltage	Liberty Pumps P/N	Macromatic P/N
Simplex, controls 1 pump	120V	K001672	SFP120A250
Duplex, controls 2 pumps	120V	K001675	SFP120C250

Power and Control Cords

⚠️ WARNING ⚡ RISK OF ELECTRIC SHOCK

- Do not remove cord and strain relief, and do not connect conduit to pump.
- Each cord has a green lead. This is the ground wire and must be grounded properly per NEC® and/or local codes.

The power and control cords are available either permanently potted into the cord cap or field-replaceable Quick-connect cords. For either option, the cords shall not be spliced.

Wiring Instructions

⚠️ WARNING ⚡ RISK OF ELECTRIC SHOCK

- Always disconnect pump(s) from power source(s) before handling or making any adjustments to either the pump(s), the pump system, or the control panel.
- All installation and maintenance of pumps, controls, protection devices, and general wiring shall be done by qualified personnel.
- All electrical and safety practices shall be in accordance with the National Electrical Code®, the Occupational Safety and Health Administration, or applicable local codes and ordinances.

Control Cord Wiring

• STANDARD QUICK-CONNECT

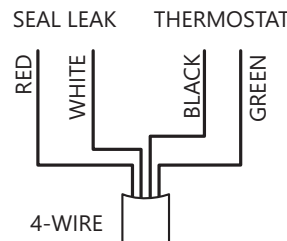

• HEAVY-DUTY QUICK-CONNECT • PERMANENT

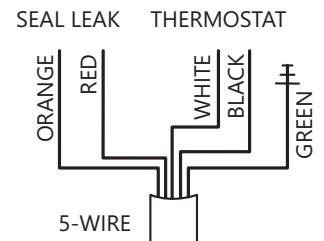

Motor Connection Wiring

200/230V 3PH (2Y)	380/400/415V 3PH (1Y)	LEAD NO.	COLOR
M1 → 1	M1 → 1	1	blue
M2 → 2	M2 → 2	2	white
M3 → 3	M3 → 3	3	orange
		4	yellow
		5	black
		6	purple
		7	pink
		8	red
		9	gray
		J	brown

Standard Quick-connect Cord

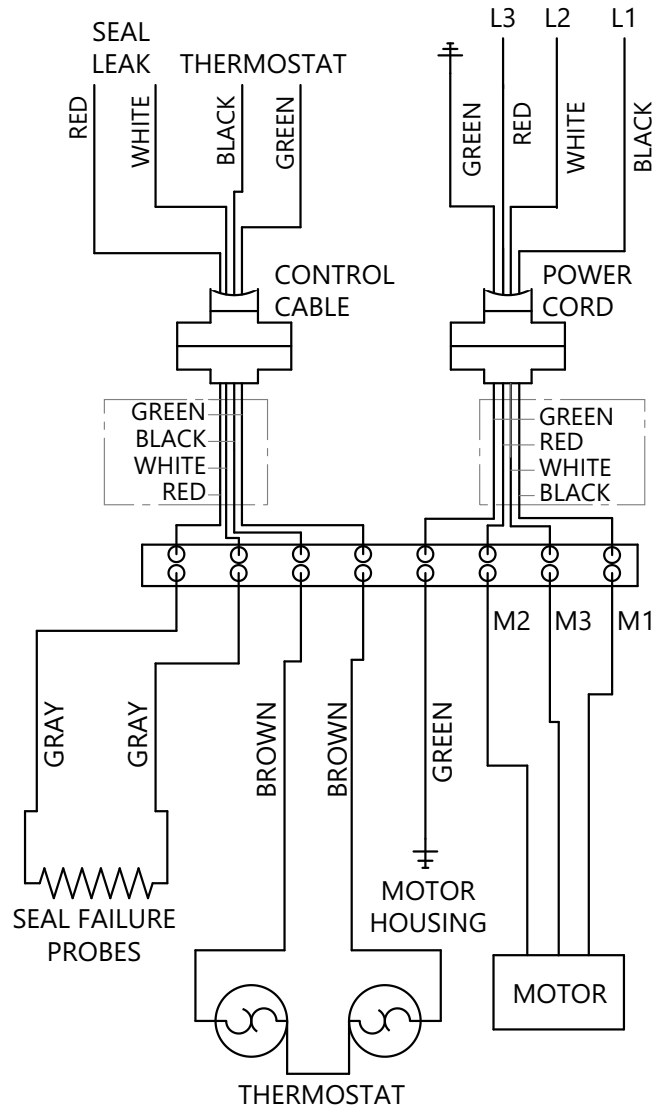

Heavy-Duty Quick-connect Cord

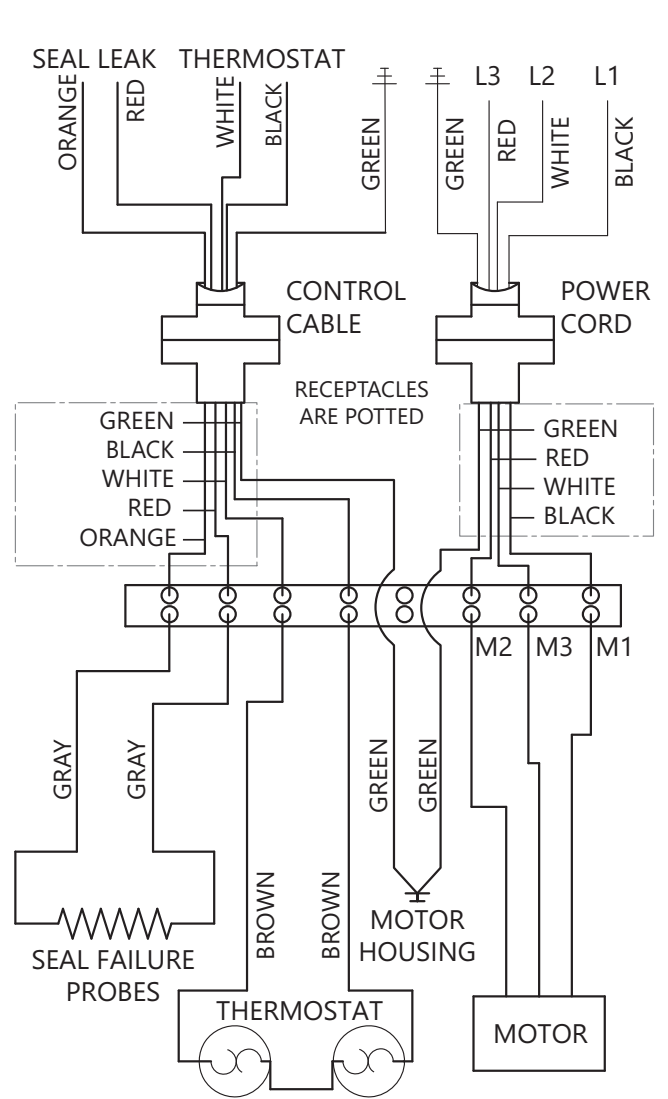

Permanent Cord

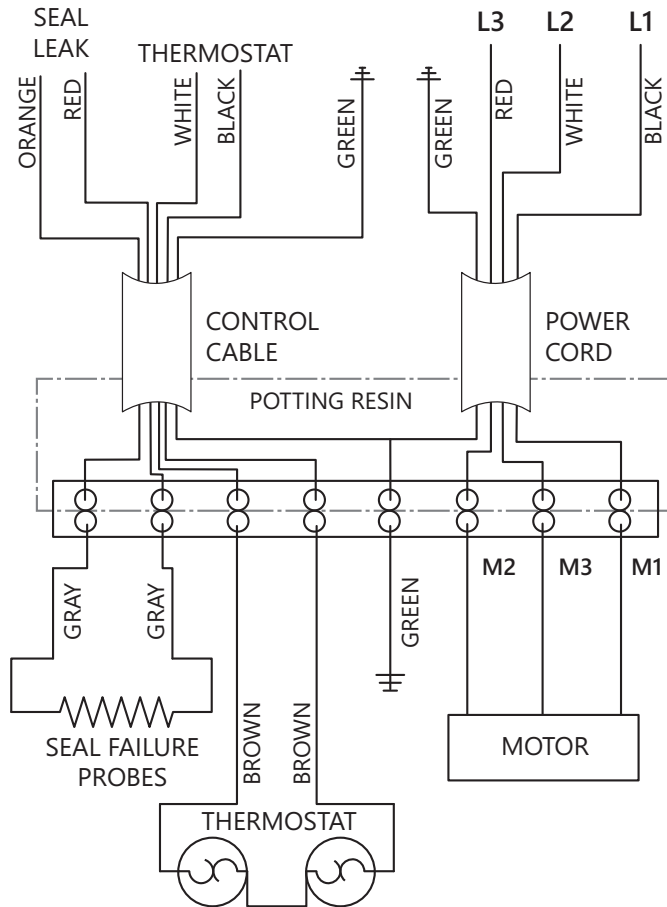

Dual Voltage Pumps

Some models are clearly identified on the pump model tag with dual voltage rating information. The pump is shipped from the factory configured for 200/230V, but can be rewired in the field to 380/400/415V. Any rewiring of a pump must be performed by qualified personnel to retain third party certifications.

Rewire Dual Voltage Pumps

Follow the steps below to access pump wiring:

1. Remove the oil plug under the warning label.
2. Unscrew the 6 socket head cap screws around the perimeter of the casting.
3. Twist while pulling upward on the casting until free from the main housing.
4. Flip the casting upside down and replace one of the screws to retain the top casting in an inverted position.
The terminal block is now accessible—reference the applicable wire schematic to rewire.
Important: Be very careful not to drop wire nuts or other debris into the motor chamber!
5. Torque terminal block screws to 20 in-lbs.
6. Once rewiring is complete, reinstall the casting.

7. Torque cap screws to 12 ft-lbs.
8. Torque oil plug to 58 ft-lbs.
9. Remove 200/230V tag from power cord. Ensure the wired voltage is clearly indicated on or inside the enclosure where the pump power cord terminates.

Verify Dual Voltage Rewiring

Perform the following electrical tests before placing pump into service:

1. Line-to-line resistance
2. Hi-pot test
3. Seal fail - 200k ohm
4. Thermal - continuity

Preparation

⚠️ WARNING ⚡ RISK OF ELECTRIC SHOCK

- Always disconnect pump(s) from power source(s) before handling or making any adjustments to either the pump(s), the pump system, or the control panel.

Install Pump Control and Alarm Floats

The water level in the sump is determined by the placement of the control floats and should be positioned such that the motor housing is completely submerged to properly cool the motor. The upper water level should be positioned to minimize pump starts. The alarm float should be above the turn-on float switch but below any inlets.

Set the second (turn-on) control above the lower turn-off control. The exact distance between the two floats must be a compromise between a frequent pumping cycle (30 starts per hour max) to properly manage sewage level, and a longer pump run duration per start, which maximizes energy efficiency. This distance shall be determined by the engineer, depending on the conditions of the application.

Prepare Basin

If replacing a previously installed pump, prepare the basin by removing the old pump and cleaning all debris from the sump. Inspect all remaining equipment in the basin including guide rails, piping, valves, and electrical junction boxes (if present) and repair or replace as appropriate. Ensure that control hardware such as floats or pressure transducers are clean, properly adjusted, and in good working order.

When installing the pump into an existing sump with a guide rail system, make certain the pump seats properly. Some vaults have angled bottoms that might interfere with the pump legs. In this application, the pump's legs should be trimmed as required. Liberty Pumps recommends leaving a portion of the leg so that the pump will stand upright when placed on the floor. Refer to reference figures.

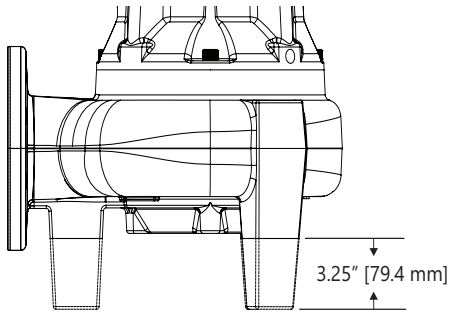

Figure 1. Cut-off Point 3-5 hp Pumps

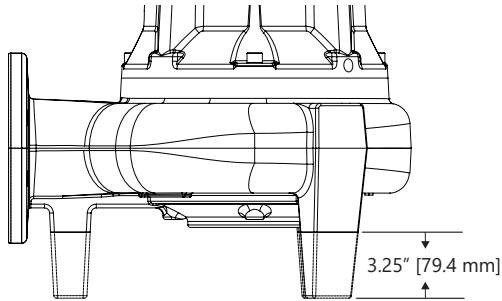

Figure 2. Cut-off Point 7.5-10 hp Pumps

Impeller Free Movement Check

Do not connect any power to pump until this check is complete. Manually rotate the impeller to check that it spins freely with very little resistance. The impeller can be rotated by reaching into the pump intake. The pump can remain upright or can be laid down on its side for easier access to the intake. Besides verification that the impeller is freely spinning, rotating the impeller helps to lubricate the shaft seals if the pump has been non-operational for more than a week. It is recommended to rotate the impeller 5-10 full rotations.

Installation

⚠ WARNING **RISK OF ELECTRIC SHOCK**

- All installation and maintenance of pumps, controls, protection devices, and general wiring shall be done by qualified personnel.
- All electrical and safety practices shall be in accordance with the National Electrical Code®, the Occupational Safety and Health Administration, or applicable local codes and ordinances.

NOTICE

- ◆ For pressure sewer applications, verify a Redundant Check Valve Assembly (curb stop and check valve) is installed between the pump discharge and the street main, as close to the public right-of-way as possible, on all installations to protect from system pressures.

Electrical Connections

With main power disconnected, complete pump and control wiring connections per wiring diagrams included with the control panel and **Wiring Instructions** section. Verify connections. Check all wires for unintentional grounds after the connections are made.

Guide Rail System

If guide rails are used, refer to the separate installation instructions supplied with the unit for proper operation.

Pump Rotation Verification

NOTICE

- ◆ Verify 3-phase pumps for correct rotation prior to installing pump(s) in basin. To change rotation, reverse any two of the three power leads to the pump (not the ground). Code the wires for reconnection after installation.

3-phase power uses three separate alternating currents that peak at different integrals. With pumps that are powered by 3-phase electric, the phase sequence of the motor must match the phase sequence of the power source. When the phase sequences match, the pump operates properly. However, when the phases are out of order, the pump runs backward (i.e., the impeller rotates in the wrong direction). This causes an extreme loss of performance and could raise the current draw, which could result in tripping an overload or circuit breaker.

To ensure that the power to the pump is installed correctly, always verify proper rotation **before** lowering it into the sump. If the pump is rotating in the wrong direction, turn off the power and reverse any two of the three power leads to the pump (not the ground). This reverses the phase sequence and corrects the pump rotation. **Rotation must be clockwise when looking from the top of the pump. The correct direction is also stamped on the bottom of the volute.**

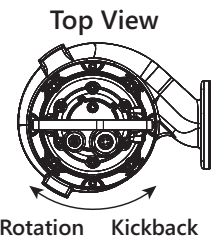

Rotation Kickback

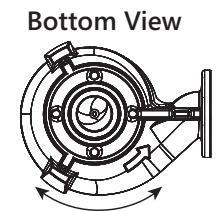

Kickback Rotation

Discharge

Make all discharge connections. A check valve is required to prevent the backflow of liquid after each pumping cycle. A gate valve should follow the check valve to allow periodic cleaning of the check valve or removal of the pump. The remainder of the discharge line should be as short as possible with a minimum number of turns to minimize friction head loss. Do not reduce the discharge to below the pump outlet size. Larger pipe sizes may be required to eliminate friction head loss over long runs. Contact Liberty Pumps or other qualified person if questions arise regarding proper pipe size and flow rates.

Pressure Sewer Applications

A redundant check valve assembly consisting of a curb stop and check valve must be installed between the pump discharge and the street main, as close to the public right-of-way as possible, on all pressure (force main) sewer installations to protect from system pressures. The curb stop valve is necessary to isolate the site from the pressure sewer while the check valve provides redundant protection against potentially detrimental backflow. All valves and fittings should be rated for at least 200 PSI service. See Liberty Pumps line of CSV-Series Curb Stop/Swing Check Valve Assemblies and CK-Series Connection Kit.

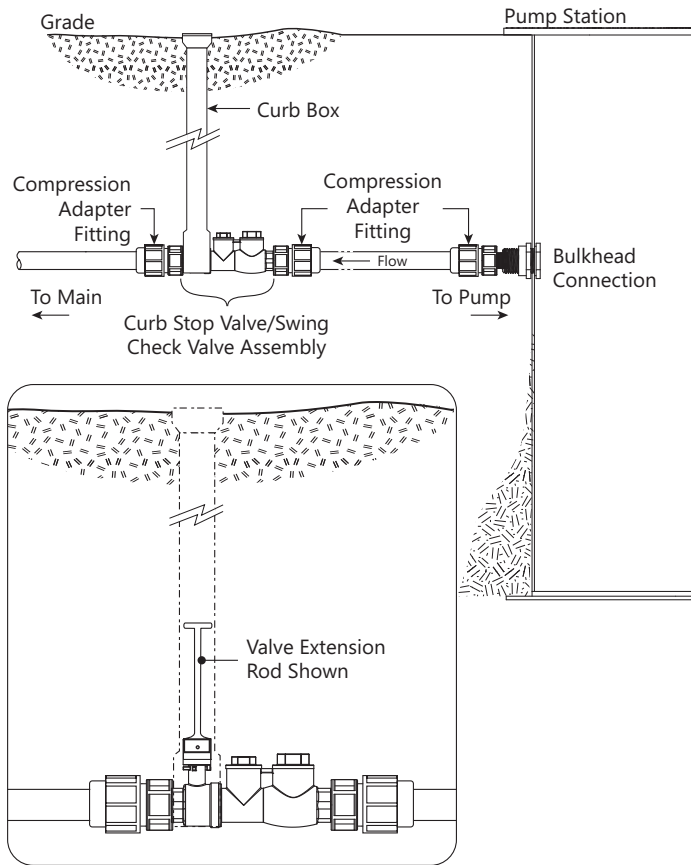

Thermostat and Seal Failure Connections

Verify thermostat wires are connected in series with the contactor, seal fail probes are properly connected, and relay sensitivity properly adjusted. Connections are provided on the terminal strip inside the Liberty Pumps control panel.

Seal leak relay setup: Turn the dial completely up, connect the leads from the pump, then push the test button. The light should turn on. While still depressing the button, turn the dial down until the light turns off, then turn the dial up until the light turns back on. For best results, the potentiometer dial should be around 160.

If the pump is connected directly to a seal leak relay in the panel (no test button), the dial should be set to around 75. Turn the potentiometer dial clockwise until the red light turns on, then turn the dial counterclockwise until the red light turns off. The tick marks on the seal leak relay are for reference only.

Vent

The fiberglass basin provided with the system must be completely sealed and properly vented per local health and plumbing code requirements. If the system is to be vented through the inlet to an existing building vent stack, there must be no traps between the system inlet and the nearest building vent stack connection (option 1). If this is not possible or desirable per the application, a standalone vent can be installed in tank side (option 2) or a vent flange or grommet can be installed in a hole cut into the cover (option 3).

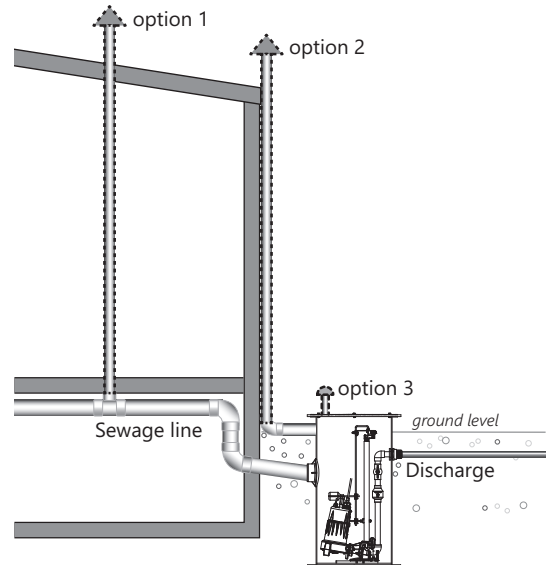

Operation

WARNING RISK OF SERIOUS INJURY OR DEATH

- Energizing the control panel or breaker for the first time is potentially dangerous. Licensed electrical personnel should be present when the panel or breaker is energized for the first time. If faults caused by damage or poor installation practices have not been detected, serious damage, injury or death can result when power is applied.

Starting System

1. Double check all wire connections.
2. If pump was rewired for dual voltage, confirm **Verify Dual Voltage Rewiring** was passed.
3. Turn pump(s) to OFF position on H-O-A switch.
4. Turn on breakers.
5. Test each pump separately in Hand mode and observe operation. If pump is noisy or vibrates, rotation is wrong. Refer to **Pump Rotation Verification**.
6. Set H-O-A switch(es) to AUTO position and allow water to rise in basin until one pump starts. Allow pump to operate until the level drops to turn-off point.

7. Allow basin level to rise to start other pump(s). Notice run lights in panel. Pumps should alternate on each successive cycle of operation.
8. Turn H-O-A switch(es) to OFF position and allow basin to fill to the override (alarm) control level(s).
9. Observe all floats in operation to verify that there is adequate clearance to the surrounds to ensure that the floats do not have the opportunity to get hung up in their travel.
10. Verify alarm system response.
11. Turn switch(es) to AUTO position; pumps should start and operate together until level drops to turn-off point.
12. Repeat this operation and cycle several times before leaving the site.
13. Check voltage when pumps are operating and record the amp draw of each pump. Check amps on each wire as sometimes a high leg will exist. For excessive voltage on one leg, the electric utility company shall be consulted.
14. Complete and submit Startup Report. Retain Report for reference. <https://www.libertypumps.com/lep/int/Services/Warranty>

Be certain to complete adequate testing, especially on systems with multiple pumps or custom control configurations.

Maintenance and Troubleshooting

⚠️ WARNING RISK OF ELECTRIC SHOCK

- Accidental contact with electrically live parts, items, fluid, or water can cause serious injury or death.
- Always disconnect pump(s) from power source(s) before handling or making any adjustments to either the pump(s), the pump system, or the control panel.

⚠️ WARNING RISK OF SERIOUS INJURY OR DEATH

- Wear adequate Personal Protective Equipment when working on pumps or piping that have been exposed to wastewater. Sump and sewage pumps often handle materials that can transmit illness or disease upon contact with skin and other tissues.
- Do not enter a pump basin after it has been used. Sewage and effluent can emit several gases that are poisonous.

NOTICE

- ◆ Replacement impellers must match the part number of original impeller installed from the factory. Do not trim impellers without consulting the factory.
- ◆ Verify correct pump rotation before returning to service.

Maintenance

As the motor is oil-filled, no lubrication or other maintenance is required.

To keep the pump/pump system operating smoothly, perform the following routine checks. Severe operating environments will require more frequent checks. For any issues that are not resolvable, contact Liberty Pumps for further assistance.

Monthly

1. Pumps that are idle for more than a month in a dry basin should have impellers manually operated through the breaker panel monthly to lubricate the seals. **Limit the lubrication run time to less than one minute per pump.**
2. Pumps that are idle in a wet basin must be removed—**do not store pump in wet basin.**

Quarterly

1. Check pumps for corrosion and wear.
2. Check for free and unobstructed float switch operation and float switch condition.
3. Inspect for proper check valve operation.
4. For multiple pumps, check for balanced operating times. Uneven times indicate a defective unit, float switch or control.
5. Inspect the control panel for any presence of moisture in enclosure, loose connections, and general component condition.

Annually

1. Basin should be inspected and cleaned. Replace any defective components.

Service

Pumps must be serviced at a qualified repair facility approved by Liberty Pumps. No repair work shall be carried out during the warranty period without prior factory approval. Any unauthorized field repairs void warranty.

Liberty Pumps, Inc. assumes no responsibility for damage or injury due to disassembly in the field. Disassembly, other than at an authorized motor enclosure repair facility approved by Liberty Pumps or its authorized service centers, automatically voids warranty.

If pumps require replacement lubrication, use ISO VG10 turbine oil (Liberty Pumps #LPOILT1032OZ) in the amounts listed. Contact Liberty Pumps to purchase quart quantities or if unsure of proper replacement procedure.

Motor chamber quantities are approximate. When refilling the motor chamber, the upper bearing should be just submerged.

Series	Motor Chamber [gal]	Seal Chamber [gal]
3LE10, 3LV10	~2	0.28
3LM07, 3LV07, 3LE07	~2.2	0.28
3LM05, 3LV05, 3LE05	~1.72	0.16
3LM03, 3LV03, 3LE03	~1.72	0.16

Troubleshooting

Refer to Table 2 for troubleshooting guidance.

Table 2. Troubleshooting Matrix

Problem	Possible Cause	Corrective Action
Pump does not start and overload heaters trip.	Unintentional ground.	Turn off power and check motor leads for possible ground.
	Motor winding failure or mis-wired motor.	Check resistance of motor windings. All three phases should have the same reading.
	Obstructed impeller or volute.	Remove obstruction.
Motor stops and then restarts after short period but overload heaters in starter do not trip.	Pump may be operating on a short cycle due to basin being too small.	A larger basin may be required. Consult Liberty Pumps.
	Water returning to basin due to leaking check valve.	Replace check valve.
Pump does not start.	Control panel selector switch in OFF position.	Set selector switch to Hand or Auto position.
	Blown control circuit transformer fuse.	Replace fuse.
	Tripped circuit breaker, blown fuse, or other interruption of power.	Reset tripped circuit breaker; replace blown fuse with properly sized fuse; investigate power interruption.
	Improper voltage.	Have an electrician check all wiring for proper connections and adequate voltage and capacity.
	Motor winding failure or mis-wired motor.	Check resistance of motor windings. All three phases should have the same reading.
	Float switch is unable to move to the pump ON position due to interference in basin or other obstruction.	Position the pump or float switch so that it has adequate clearance for free movement.
	Insufficient liquid level.	Verify the liquid level is allowed to rise enough to activate float switch(es).
	Defective float switch.	Replace float switch.
	Obstructed impeller or volute.	Remove obstruction.
	Loose wiring connections.	Check and tighten all connections.
	Thermal overload tripped.	Wait for pump to cool to operating temperature.
Pump does not deliver proper capacity.	Discharge gate valve partially closed or clogged.	Check the discharge line for foreign material, including ice if the discharge line passes through or into cold areas.
	Check valve partially clogged.	Raise liquid level up and down to clear; remove check valve to remove obstruction.
	Incorrect motor rotation.	Correct pump rotation direction. Refer to section Pump Rotation Verification .
	Low liquid level.	Check liquid level.
	Obstruction in pump or piping.	Remove obstruction.
	Total head is beyond pump's capability.	Route discharge piping to a lower level. If not possible, a larger pump may be required. Consult Liberty Pumps.

Table 2. Troubleshooting Matrix (continued)

Problem	Possible Cause	Corrective Action
Pump runs but does not turn off.	Pump is air-locked.	Turn pump off and let set for several minutes, then restart.
	Float switch unable to move to the pump OFF position due to interference with the side of basin or other obstacle.	Position the pump or float switch so that it has adequate clearance for free movement.
	Control panel selector switch in Hand position.	Set selector switch to Auto position.
	Control panel failure.	Check control panel.
	Defective float switch.	Replace float switch.
	Missing or faulty curb stop/swing check valve allowing system pressure to feed back through discharge piping.	Verify presence of a curb stop check valve or replace curb stop/swing check valve assembly.
Pump operates with selector switch in Hand position but does not operate in Auto position.	Control circuits malfunctioning.	Check float switch, level control or alternator relay for issues. Replace as necessary.
		Check control panel.
Pump cycles too frequently.	Improper float switch setting.	Adjust float switch setting.
	Check valve not installed, stuck open, or leaking.	Install check valve(s); remove check valve and examine for freedom of operation and proper installation.
	Missing or faulty curb stop/swing check valve allowing system pressure to feed back through discharge piping.	Verify presence of a curb stop check valve or replace curb stop/swing check valve assembly.
Repeated tripping.	Circuit protection underrated.	Check rating and replace with proper size.
	Current unbalance.	Check current draw.
	Other appliance on same circuit.	Pump requires separate circuit.
	Pump is connected to an extension cord or wiring is inadequate or compromised.	Have an electrician check for proper wiring.
	Improper voltage.	Have an electrician check all wiring for proper connections and adequate voltage and capacity.
	Obstruction in pump.	Remove obstruction.
	Incorrect motor rotation.	Correct pump rotation direction. Refer to section Pump Rotation Verification .
	Foreign matter build-up.	Clean motor housing.

Table 2. Troubleshooting Matrix (continued)

Problem	Possible Cause	Corrective Action
Pump runs or hums but does not pump.	Discharge line blocked or restricted.	Check the discharge line for foreign material, including ice if the discharge line passes through or into cold areas.
	Check valve is stuck closed or installed backward.	Remove check valve(s) and examine for freedom of operation and proper installation.
	Gate or ball valve is closed.	Open gate or ball valve.
	Total head is beyond pump's capability.	Route piping to a lower level. If not possible, a larger pump may be required. Consult Liberty Pumps.
	Obstructed impeller or volute.	Remove obstruction.
	Pump is air-locked.	Turn pump off and let set for several minutes, then restart.
		Add baffle to reduce trapped air bubbles.
	Capacitor failure in control panel.	Check capacitors and replace if needed.
	Stuck/defective motor contactor in control panel.	Replace motor contactor.
Pump is not seated correctly in guide rail base.	Lift pump and re-position.	
High level alarm triggering.	Missing or faulty curb stop/swing check valve allowing system pressure to feed back through discharge piping.	Verify presence of a curb stop check valve or replace curb stop/swing check valve assembly.
Seal fail light is illuminated.	Lower (outer) seal has been compromised.	Replace lower seal.
	Control panel relay sensitivity is incorrect.	Adjust sensitivity dial.
Pump runs periodically when fixtures are not in use.	Check valve not installed, stuck open, or leaking.	Install check valve(s); remove check valve and examine for freedom of operation and proper installation.
	Fixtures are leaking.	Repair fixtures as required to eliminate leakage.
Pump operates noisily.	Piping attachments to building are too rigid.	Replace a portion of the discharge line with rubber hose or connector.
	Incorrect motor rotation.	Correct pump rotation direction. Refer to section Pump Rotation Verification .
	Pump is being run below minimum head requirement causing cavitation.	A different sized pump or impeller may be required. Consult Liberty Pumps.
	Foreign objects in the impeller cavity.	Clean the impeller cavity.
	Broken impeller.	Consult Liberty Pumps for information regarding impeller replacement.
Worn bearings.	Return pump to an authorized repair facility.	
Rupture or failure of discharge plumbing either inside or outside of the basin.	Missing or faulty curb stop/swing check valve allowing system pressure to feed back through discharge piping.	Verify presence of a curb stop check valve or replace curb stop/swing check valve assembly.

Warranty

Liberty Engineered Products Limited Warranty

Liberty Pumps, Inc. warrants that pumps of its Engineered Product line are free from all factory defects in material and workmanship for a period of 18 months from the date of installation or 24 months from the date of manufacture, whichever occurs first, and provided that such products are used in compliance with their intended applications as set forth in the Liberty Engineered Products specifications and technical manuals. The date of installation shall be determined by a completed pump start-up report and warranty registration form.

A pump startup report, filled out by a qualified installer, is required for warranty to take effect. The report must be submitted within 30 days from the installation date and submitted through the Liberty Pumps website. During the warranty period, the manufacturer's obligation, and at its discretion, shall be limited to the repair or replacement of any parts found by the manufacturer to be defective, provided the product is returned freight prepaid to the manufacturer or its authorized service center, and provided that none of the following warranty-voiding characteristics are evident:

The manufacturer shall not be liable under this Warranty if the product has not been properly installed or maintained in accordance with the printed instructions provided; if it has been disassembled, modified, abused or tampered with; if the pump discharge has been reduced in size; if the pump has been used in water temperatures above those shown in the specifications; if the thermal overload(s) and seal moisture probe(s) have not been properly connected (where equipped); if the pump has been used in water containing sand, lime, cement, gravel or other abrasives; if the product has been used to pump chemicals or hydrocarbons; if the product has been moved from its original installation location, or if the label bearing the serial and code number has been removed.

Liberty Pumps, Inc. shall not be liable for any loss, damage or expenses resulting from installation or use of its products, or for consequential damages, including field labor costs, travel expenses, rental equipment, costs of removal, reinstallation or transportation to and from the factory or an authorized Liberty Pumps repair facility.

There is no other express warranty. All implied warranties, including those of merchantability and fitness for a particular purpose, are limited to 18 months from the date of installation or 24 months from the manufacturing date. This Warranty contains the exclusive remedy of the purchaser, and, where permitted, liability for consequential or incidental damages under any and all warranties are excluded.

<https://www.libertypumps.com/lep/int/Services/Warranty>